



FLYT

assembly **INSTRUCTIONS**

A | M | Q



Standard Components

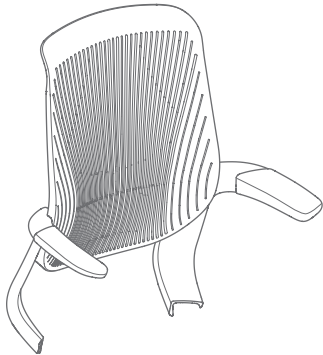

Seat Back

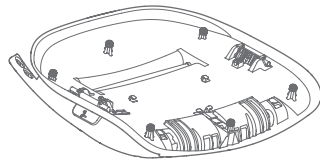

Seat Pan

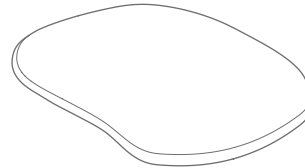

Seat Cover

ships in separate box



Castors



Gas Lift

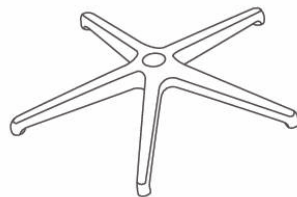

Star Base

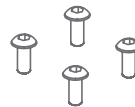

4 Bolts

Tools Required

5mm Allen Key

Optional Component

Drafting Ring Lift Extension
optional accessory –
separate box

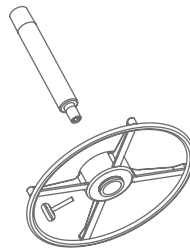

Installation Notes

- Please read the assembly instruction sheet completely before assembly.
- Remove all parts from carton and check that all parts are included prior to assembly.
- Assemble the chair on the carton or table to prevent scratching the chair.
- Please be mindful of the weight of chair to avoid injury.
- Do not use power tools.
- Examine all packaging material and remove staples before discarding carton.
- The parts of the product may be slightly different from the drawings shown.
- For assistance, contact Customer Care at (877) 801-0370



Assembly

Step 1 — Frame Assembly

Select a smooth surface in order not to scratch the parts.

1. Attach the Back to the Seat Pan with the 4 bolts (2 per side).
2. Insert the Seat Cushion into the Seat Pan.
3. Attach with 4 bolts provided.

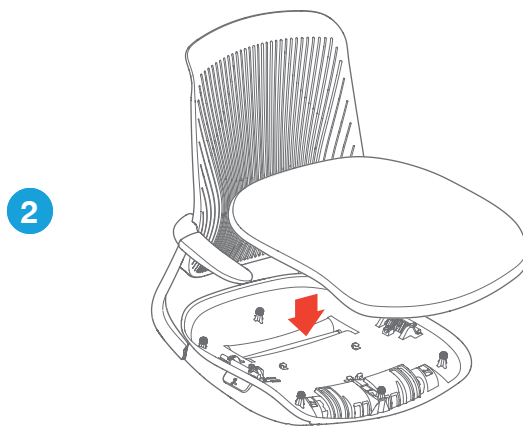
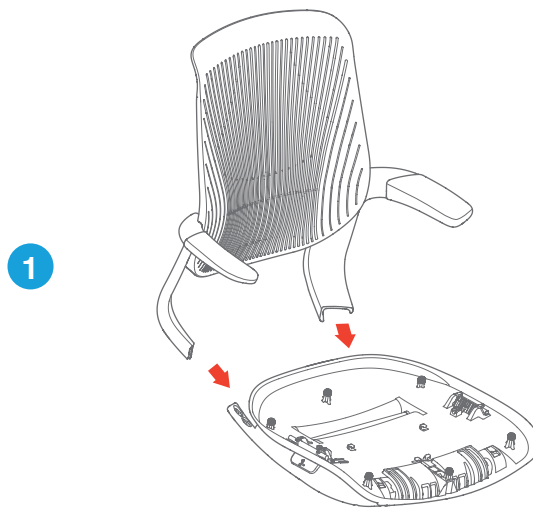



Step 2 — Casters, Star Base and Gas Lift Assembly

Select a smooth surface in order not to scratch the parts.

1. Turn the Star Base upside down and press Casters into holes at the end of each leg.
2. Turn the Star Base upright and insert the Gas Lift into the center hole of Star Base.

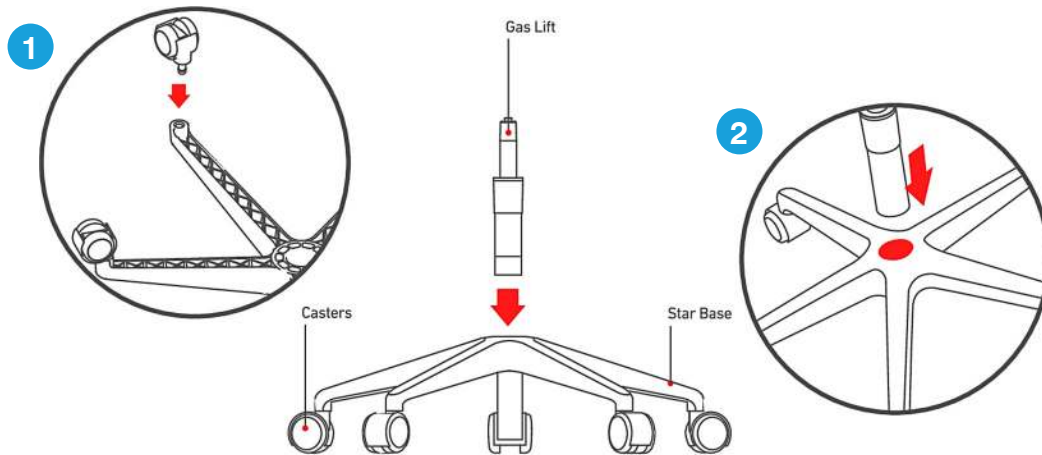

Step 3 — Final Assembly

1. Combine the upper part of the chair with the already assembled bottom part.
2. **If Drafting Ring is included, see below before doing this step.**
Fix the cylinder to the hole located below the upper part of the chair.
3. After installing the cylinder, sit on the chair and check if the chair height adjustment lever is fully functional.

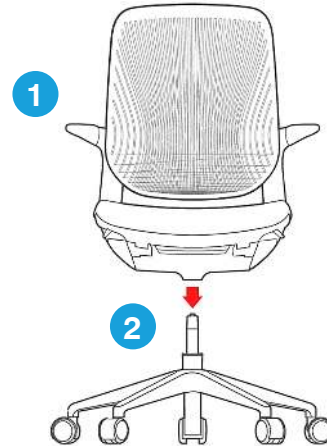

Optional Drafting Ring Lift Extension

1. Insert cylinder into ring. Tighten with knob.
2. Slide the cylinder into the 5-star base.

